

ARTICULATING BOOM

HA 15 IP



- 140° (+70°/-70°) fly jib range of motion.
- 27 ft 10 in (8.5 m) outreach.
- 6 ft 6 in (2 m) stowed height.
- 4 ft 11 in (1.5 m) width.
- Full electric drive.
- 12 hrs operating autonomy.



The Haulotte® advantages

- Full electric drive
- Zero tailswing
- 6 ft 6 in (2 m) stowed height for easy travel through door ways
- 12 ft 1 in (3.7 m) short turning radius and 4 ft 11 in (1.50 m) width allows operation in the most congested areas
- Full proportional control station
- Work platform control
- Improved safety due to load limiter in the basket
- Robust, reliable and easy to maintain

STANDARD FEATURES

- 360 Ah traction batteries
- Battery charge indicator
- 48 V – 50 A on-board battery charger
- Sensitive control box
- 3° tilt alarm
- Non marking tyres
- Outside / inside use: wind rated to 45 km/h (28 mph)
- Free wheeling device
- Hourmeter
- Turret slewing lock pin
- Towing hooks / lifting eyes
- Manual emergency lowering pump
- 2 front wheel drive and 2 rear steering wheels
- Load limiter in cage
- Horn

OPTIONS & ACCESSORIES

- Flashing light
- Socket (220V) in the basket
- Travel alarm
- Centralized battery filling kit
- Waterproof batteries
- Air line to cage
- Brakes remote release control box from lower control box
- Biodegradable oil
- Large basket option (1,5m x 0,8m / 59 in X 32 in)

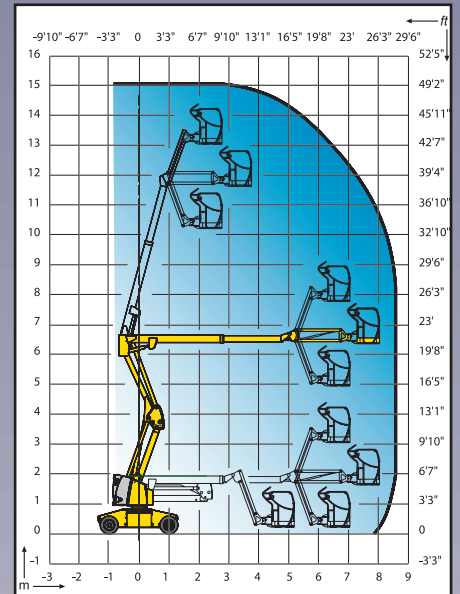
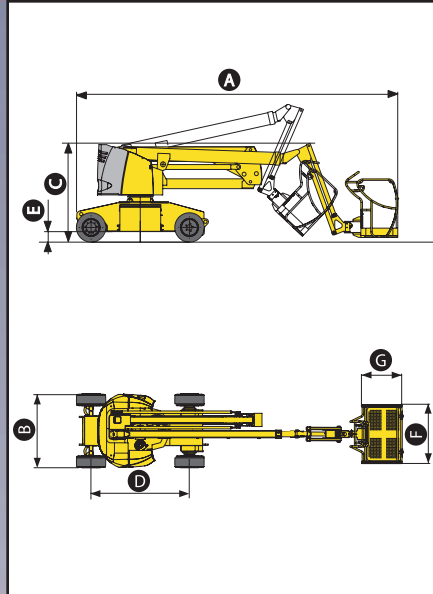

SPECIFICATIONS

Working height	49 ft 2 in	15.0 m
Platform height	42 ft 8 in	13.0 m
Maximum outreach	27 ft 10 in	8.50 m
Up and over clearance	21 ft 8 in	6.60 m
Capacity platform	507 lb	230 kg
Fly jib range of motion	140° (+70°/-70°)	140° (+70°/-70°)
A Length	21 ft 7 in	6.60 m
B Width	4 ft 11 in	1.50 m
C Stowed height	6 ft 6 in	2.0 m
D Wheelbase	6 ft 6 in	2.0 m
E Ground clearance	6 in	0.15 m
F x G Platform size	47 in X 32 in	1.2 x 0.8 m
Travel / transport length	17 ft 7 in	5.50 m
Travel / transport height	9 ft 2 in	3.00 m
Driving speed	0.4 -3.1 mph	0.7 / 5 km/h
Outside turning radius	12 ft 2 in	3.70 m
Turret rotation	350°	
Hydraulic platform rotation	180°	
Energy	48 V - 360 Ah batteries	
Gradeability	25%	
Non marling tyres	23 X 10 X 12	
Hydraulic tank	8 gallons	50 l
Total weight	16.097 lb	7.490 kg

AS 1418.10

