

HA 16 PX HA 18 PX



- Max. 35 ft (10.60 m) horizontal outreach (HA18PX).
- 50% gradeability.
- 16 in (40 cm) ground clearance.
- Standard 4 wheel drive and steer.
- Soft, proportional and simultaneous movements.



HA 16 PX HA 18 PX

Articulating boom

The Haulotte® advantages

- 52 ft and 57 ft (16 and 18 m) working heights
- Hydraulic differential lock and 16 in (40 cm) ground clearance for improved rough terrain capability
- Gradeability up to 50%
- Continuous 360° turntable rotation
- 45 sec. lift speed to full height
- Full proportional controls and simultaneous boom functions improve productivity
- Load control in cage
- Improved working area through a positive / negative articulating fly jib with 140° movement
- Zero tailswing
- 180° hydraulic platform rotation
- Improved design for travel / transport (HA 16 PX: 5.25 m / 17 ft 3 in transport length)
- Robust, reliable and easy to maintain design
- Improved safety due to load limiter in the basket

STANDARD FEATURES

- 4 wheel drive and steer
- Swing out engine tray for easier maintenance
- 72 l (16 gal) fuel tank; 1.50 m filling height
- 5° tilt alarm
- 12 V battery / electrical control system
- Battery electric emergency control in cage
- Free wheeling device
- Hourmeter
- Slewing block pin
- Towing hooks / lifting eyes

OPTIONS & ACCESSORIES

- Dual Gas / Fuel engine (GM 1.6 L / 23 kW)
- 3.3 kW on-board generator
- 230 V / 115 V - 16 A power line in cage
- Large basket 91 x 32 in (2.3 x 0.80 m)
- Travel alarm
- Rotating beacon
- Working light
- Catalytic exhaust
- Encoded starting device
- Biodegradable hydraulic oil
- Cold countries kit
- Hot countries kit

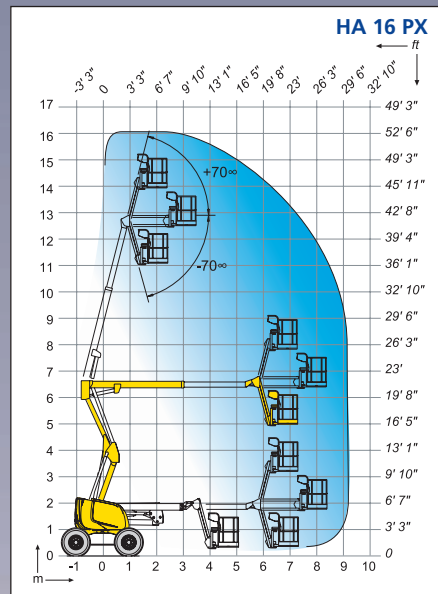
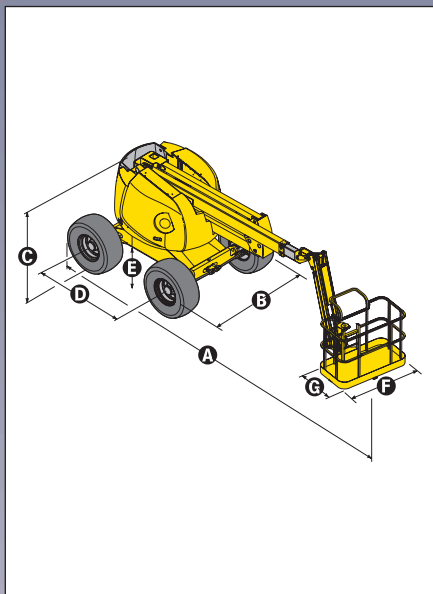

SPECIFICATIONS

	HA 16 PX		HA 18 PX	
Working height	16.0 m	52 ft	17.3 m	56 ft 2 in
Platform height	14.0 m	46 ft 3 in	15.3 m	50 ft 6 in
Maximum outreach	9.1 m	30 ft 10 in	10.60 m	35 ft
Up and over clearance	6.60 m / 21 ft 8 in			
Platform capacity	230 kg / 507 lb			
Fly jib range of motion	140° (+70° / -70°)			
A Stowed length	6.95 m	22 ft 10 in	7.60 m	24 ft 11 in
B Width	2.30 m / 7 ft 7 in			
C Stowed height	2.20 m / 7 ft 3 in			
D Wheelbase	2.0 m / 6 ft 7 in			
E Ground clearance	40 cm / 16 in			
F x G platform size	1.8 m x 0.8 m / 71 in x 32 in			
Travel / transport length	5.25 m	17 ft 3 in	5.90 m	19 ft 4 in
Travel / transport height	2.20 m / 7 ft 3 in			
Tailswing	0			
Drive speed	0.8-5.5 km/h / 0.5-3.4 mph			
Outside turning radius	4 m / 13 ft 1 in			
Inside turning radius	1.9 m / 6 ft 3 in			
Turntable rotation (continuous)	360°			
Hydraulic platform rotation	180°			
Engine	Deutz Diesel 42 cv - 31kW			
Gradeability	50%			
Tyres (foam filled)	385/65-22.5			
Hydraulic tank	100 l / 26 gal			
Fuel tank	72 l / 19 gal			
Weight	6,900 kg	15,964 lb	7,850 kg	17,905 lb

AS 1418.10



HAULOTTE UK LTD • STAFFORD PARK 6 • TELFORD - SHROPSHIRE TF3 3AT • TEL: +44 (0)1952 292753 • FAX: +44 (0)1952 292758 • E-mail: haulotte@haulotte.co.uk
 HAULOTTE SCANDINAVIA AB • ARÖDS INDUSTRIÄG 66 B • 422 43 HISINGS BACKA - SWEDEN • TEL: +46 31 744 32 90 • FAX: +46 31 744 32 99 • E-mail: hwallin@haulotte.se • www.haulotte.se
 HAULOTTE AUSTRALIA PTY LTD • 65 LICOLA CRES • DANDENONG - VIC - 3175 • TEL: +61 (0)3 9706 6787 • FAX: +61 (0)3 9706 6797 • E-mail: sales@haulotte.com.au
 HAULOTTE SINGAPORE PTE. LTD • 26 Changi North Road Way • SINGAPORE 498812 • TEL: +65 6536 3989 • FAX: +65 6536 3969 • E-mail: haulotteasia@haulotte.com

Haulotte 
GROUP

Haulotte Group - La Péronnière - BP 9 - 42152 l'Homme - France • Tél : +33 (0)4 77 29 24 24 - Fax : +33 (0)4 77 29 43 95
 e.mail - haulotte@haulotte.com • web : http://www.haulotte.com

2420604080 - Ed. 02/2006 - Copyright © by Pinguely-Haulotte - products specifications are subject to change without notice - non contractual pictures.