

ROUGH-TERRAIN SCISSOR LIFTS

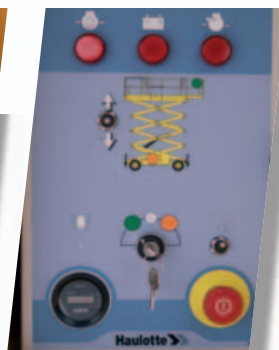

H 12 SX
H 15 SX
H 18 SX



- 19 ft 5 in X 5 ft 10 in (6 m x 1.8 m) platform.*
- 1.980 lb (900 kg) lift capacity.
- 40% gradeability.
- Standard 4 wheel drive.

* with both extension decks fully extended.



H 12 SX
H 15 SX
H 18 SX

Rough-terrain scissor lifts

The Haulotte® advantages

- Double extension for increased working area
- Hydraulic differential lock for improved rough terrain capability
- 35 cm / 14 in ground clearance ensures exceptional rough terrain performance
- Tight turning radius ensuring an excellent manoeuvrability
- Maximum drive speed : 6 km/h / 3,7 mph
- Compact stowed height and width makes transport and manoeuvrability easier
- Foam filled tyres
- Full proportional controls
- Load limiter in cage
- Robust, reliable and easy to maintain design

STANDARD FEATURES

- Hatz "silent pack" diesel engine
- 4 wheel drive (2 front steering wheels)
- 5° tilt alarm
- 1 m / 3 ft 3 in double extension
- Load limiter in cage
- 12 V - 95 Ah batteries
- 14 V - 50 A alternator
- Removable operator's control box
- Free wheeling device
- Hourmeter
- Horn
- Towing hooks
- Hydraulic brakes
- Hydraulic stabilisers
- Manual emergency lowering system
- Automatic levelling outriggers

OPTIONS & ACCESSORIES

- Catalytic exhaust
- Rotating beacon
- Travel alarm
- Mains power outlet on platform
- Working light
- Encoded starting device
- Biodegradable hydraulic oil
- Motion alarm for movements and translation
- Non-marking tyres
- Hot weather kit
- Automatic hydraulic levelling jacks (standard on H18SX)
- Dual fuel engine, GM 1.6l - 41 hp (30.6kW)
- 3kW generator

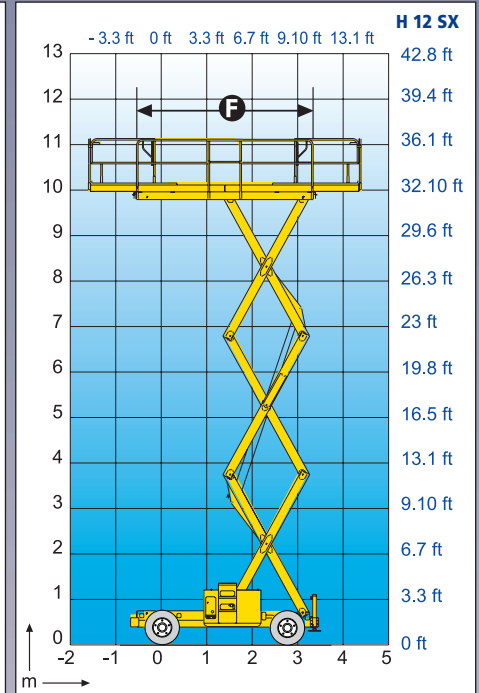
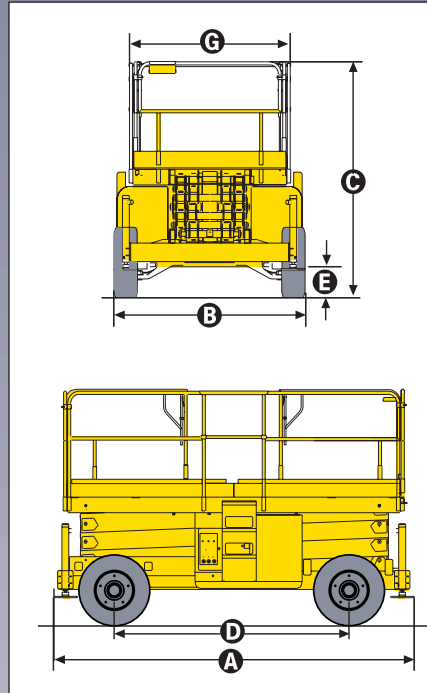

SPECIFICATIONS

	H 12 SX		H 15 SX		H 18 SX	
Working Height	39ft	12 m	49ft	15 m	59ft	18 m
Platform Height	32 ft 9 in	10 m	42 ft 7 in	13 m	52 ft 5 in	16 m
Platform Capacity (one extension)	1.984 lb	900 kg	1.543 lb	700 kg	1.323lb	600 kg
Maximum Capacity (two extensions)	1.540 lb	700 kg	1.100 lb	500 kg	1.100 lb	500 kg
A Length	13 ft 6 in / 4.12 m					
B Width	7 ft 4 in / 2.25 m					
C Stowed Height	8 ft 5 in	2.57 m	9 ft	2.75 m	9 ft 8 in	2.96 m
Travel/transport Height	4 ft 6 in	1.71 m	5 ft 2 in	1.90 m	5 ft 10 in	2.11 m
D Wheelbase	9 ft / 2.75 m					
E Ground clearance	14 in / 35 cm					
F x G Platform size	194 in X 71 in / 4.0 m x 1.89 m					
Platform extension	3 ft 3 in / 1 m					
Extension capacity	440 lb / 200 kg					
Drive speed	0.4/3.7 mph / 1.6 / 6 km/h					
Outside turning radius	16 ft 3 in / 4.96 m					
Raise / Lower speed	43 / 65 sec.		46 / 57sec.		60 / 60 sec.	
Power source	Diesel 32 hp - 24 kW / Diesel 32CV - 24 kW					
Gradeability	40%					
Tilt alarm	5°		5°		3°	
Tyres (Foam Filled)	10 x 16.5"					
Hydraulic tank	26 gallons - 100 l					
Fuel tank	17 gallons - 65 l					
Weight	11.600lb	5.350 kg	13.560 lb	6.180 kg	15.970 lb	7.300 kg

AS1418.10



2420603700 - Ed. 03/2006 - Copyright © by Pinguely-Haulotte - products specifications are subject to change without notice - non contractual pictures.

HAULOTTE UK LTD • STAFFORD PARK 6 • TELFORD - SHROPSHIRE TF3 3AT • TEL : +44 (0)1952 292753 • FAX : +44 (0)1952 292758 • E-mail : haulotte@haulotte.co.uk
 HAULOTTE SCANDINAVIA AB • ARÖDS INDUSTRIVÄG 66 B • 422 43 HISINGS BACKA - SWEDEN • TEL : +46 31 744 32 90 • FAX : +46 31 744 32 99 • E-mail : hwallin@haulottese.se • www.haulotte.se
 HAULOTTE AUSTRALIA PTY LTD • 65 LICOLA CRES • DANDENONG - VIC - 3175 • TEL : +61 (0)3 9706 6787 • FAX : +61 (0)3 9706 6797 • E-mail : sales@haulotte.com.au
 HAULOTTE SINGAPORE PTE. LTD • 26 Changi North Road Way • SINGAPORE 498812 • TEL : +65 6536 3989 • FAX : +65 6536 3969 • E-mail : haulotteasia@haulotte.com

Haulotte
 GROUP

Haulotte Group - La Péronnière - BP 9 - 42152 l'Homme - France • Tél : +33 (0)4 77 29 24 24 - Fax : +33 (0)4 77 29 43 95
 e.mail - haulotte@haulotte.com • web : http://www.haulotte.com